

VentA Hood® ISLAND RANGE HOOD SPECIFICATIONS

CO/COH "H" in part number indicates halogen lighting. This model not available with heat lamps. Shown with optional duct cover (sold separately). Optional duct covers available in standard and custom sizes.

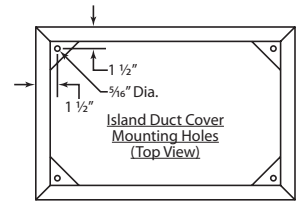

Connection Diagram (36" - 54")

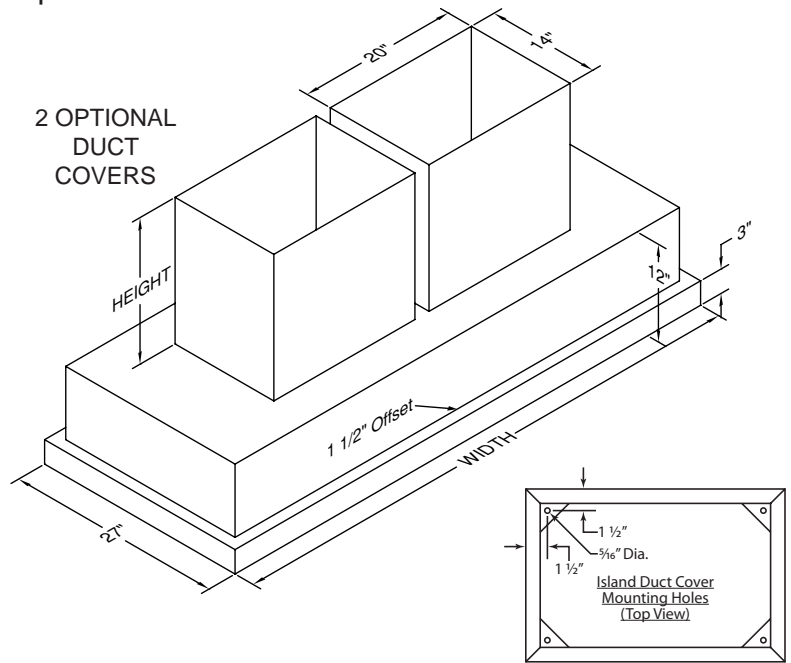
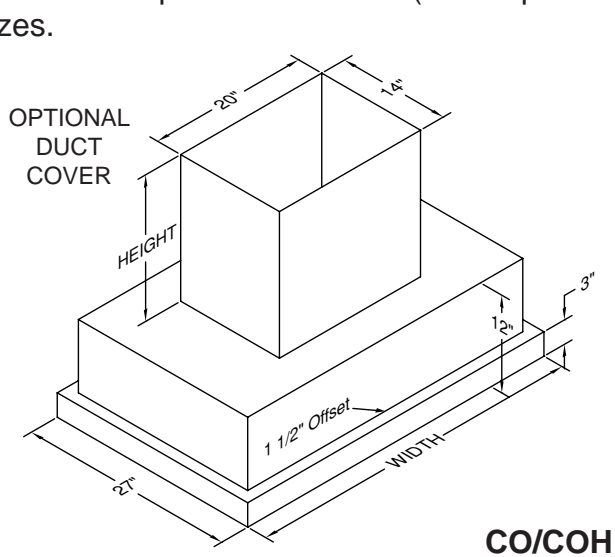
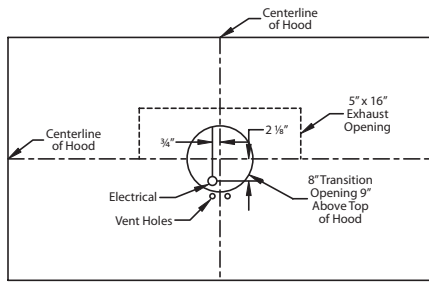

550 CFM T200 Dual Blower (Top View)

Connection Diagram (60" - 66")

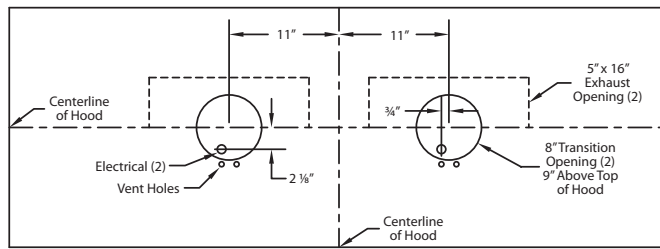

1100 CFM T2+ 200 Dual Blowers (Top View)

Recommended Mounting Height*

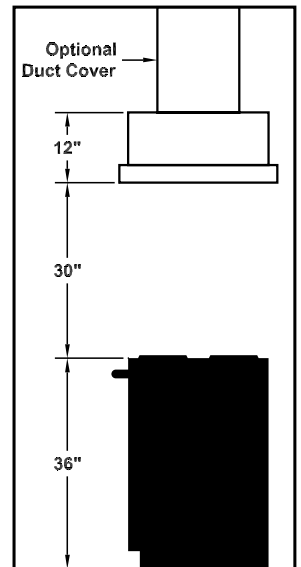

*Exceeding recommended mounting height may compromise performance.

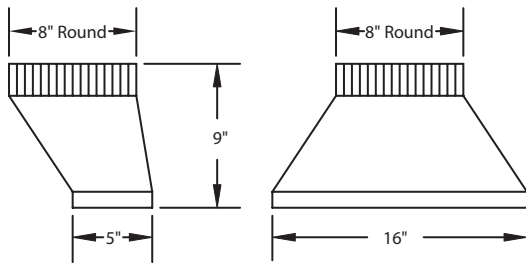

VP565 Standard Transition (Included)

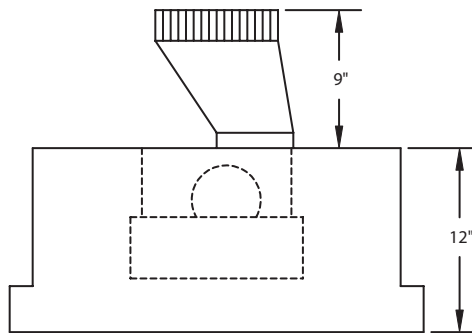

Transition Installed (Side View)

Electrical/Mechanical Specifications For Blower Units

Model	Volts	Amps*	Hz	RPM	CFM SP@0.0"	Equivalent CFM*	CFM SP@0.1"	CFM SP@0.2"	CFM SP@0.3"	Minimum Round Duct Size	Sones#
T200 Island Dual	115	2.9	60	1550	550	900	507	471	431	8" (50 in. ²)	6.0

* Add 0.5 amp for each halogen light. Hood is available with fluorescent lights (two for each dual blower) or with halogen lights (one in each corner).
 # Because the Magic Lung® blower uses centrifugal filtration rather than conventional baffle or mesh filters, the Magic Lung® blower can handle cooking equipment with higher cubic feet per minute (CFM) requirements and can deliver equivalent CFM much more efficiently than other filtration systems. When comparing the Magic Lung® with other blower units made by other manufacturers, use the "Equivalent CFM".
 # Ratings in accordance with the Standard Test Code by the Energy Systems Laboratory of the Texas Engineering Experiment Station.