

VentA Hood® WALL MOUNT RANGE HOOD SPECIFICATIONS

CWUH9 Equipped with LED lighting. Not available with heat lamps. Shown with optional duct cover (sold separately). Optional duct covers available in standard and custom sizes. Mirror stainless steel inserts (hood and duct cover) included.

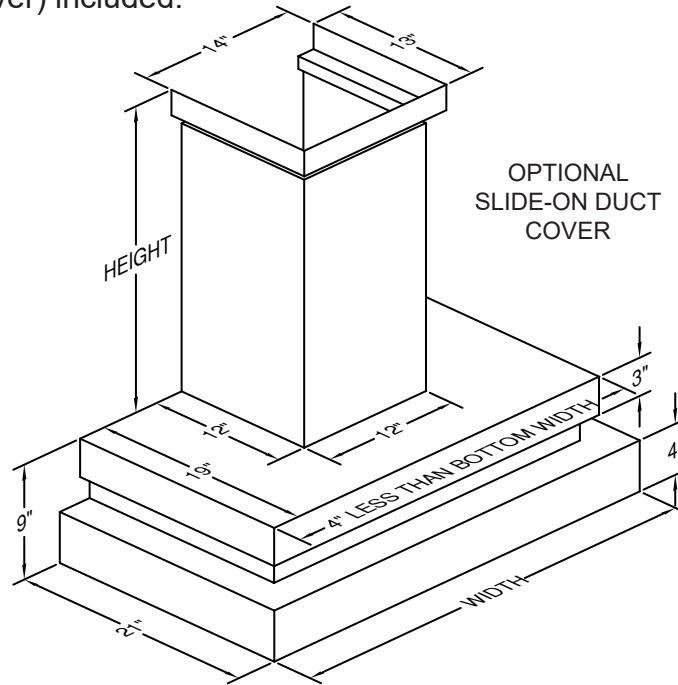

Connection Diagram (30" - 48" Widths)

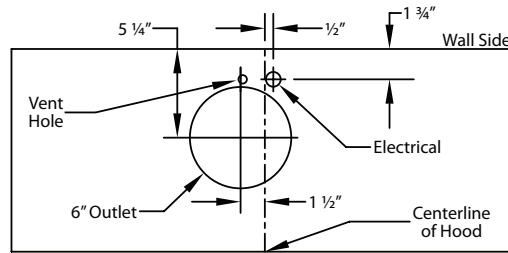

300 CFM B100 Single Blower (Top View)

Connection Diagram (30" - 54" Widths)

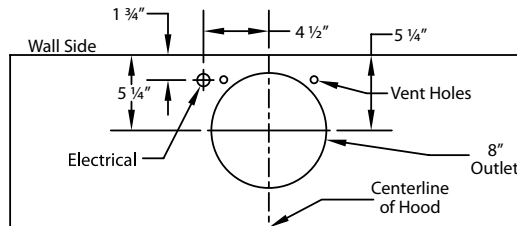

600 CFM B200 Dual Blower (Top View)

Recommended Mounting Height

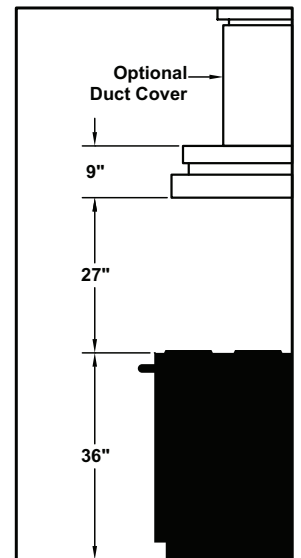

*Recommended mounting height is for optimum performance.

Electrical/Mechanical Specifications For Blower Units

Model	Volts	Amps	Hz	RPM	CFM SP@0.0"	Equivalent CFM*	CFM SP@0.1"	CFM SP@0.2"	CFM SP@0.3"	Minimum Round Duct Size	Sones#
B100 Single	115	2.5	60	1550	300	450	273	245	225	6" (28 in. ²)	5.4
B200 Dual	115	4.0	60	1550	600	900	531	480	430	8" (50 in. ²)	6.5

Hood is available with LED lights (2 lights: 30" - 41", 3 lights: 42" - 48", 4 lights: 54").

* Because the Magic Lung® blower uses centrifugal filtration rather than conventional baffle or mesh filters, the Magic Lung® blower can handle cooking equipment with higher cubic feet per minute (CFM) requirements and can deliver equivalent CFM much more efficiently than other filtration systems. When comparing the Magic Lung® with other blower units made by other manufacturers, use the "Equivalent CFM".

Ratings in accordance with the Standard Test Code by the Energy Systems Laboratory of the Texas Engineering Experiment Station.

SPECIFICATIONS SUBJECT TO CHANGE WITHOUT NOTICE Rev. 0516A

